



INSTALLATION INSTRUCTIONS FOR PART 99-8905B

APPLICATIONS

Subaru Impreza 2012-up 99-8905B



KIT FEATURES

- ISO DIN radio provision with pocket
- **Painted Matte Black**

KIT COMPONENTS

- A) Radio Trim Panel • B) Radio Brackets • C) Pocket • D) Four #8 x 3/8" Phillips screws

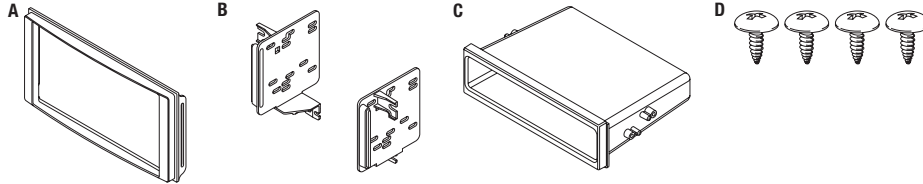

WIRING & ANTENNA CONNECTIONS (sold separately)

Wiring Harness: • 70-7552 Nissan Harness 2007-up

Antenna Adapter: • Not Required

TOOLS REQUIRED

- Panel removal tool • Phillips screwdriver • Small Flat Blade Screwdriver

Table of Contents

Dash Disassembly

- Subaru Impreza 2012-up 2

Kit Assembly

- ISO DIN radio provision..... 3

CAUTION: Metra recommends disconnecting the negative battery terminal before beginning any installation. All accessories, switches, and especially air bag indicator lights must be plugged in before reconnecting the battery or cycling the ignition.

NOTE: Refer to the instructions included with the aftermarket radio.

REV 11/27/2012 INST99-8905B



99-8905B

Dash Disassembly

1. Disconnect air selector cable on driver's side of center console behind dash above accelerator pedal. (Figures A and B)
2. Open glove box and squeeze in on sides of box to remove entire glove box.
3. Disconnect temperature selector cable on passenger side of center console behind glove box. (Figure C)

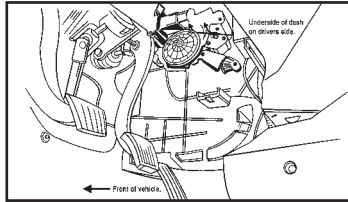

(Figure A)

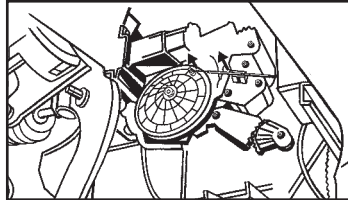

(Figure B)

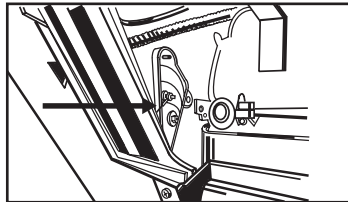

(Figure C)

4. Unclip and remove the trim panel surrounding the factory radio including the a/c vents and climate controls. (Figure D)
5. Remove (4) Phillips from the factory radio. (Figure E)

Continue to kit assembly

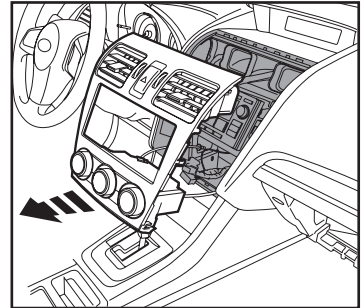

(Figure D)

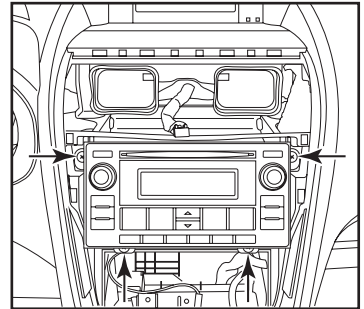

(Figure E)



99-8905B

Kit Assembly

ISO DIN radio provisions with pocket

1. Attach the brackets to the radio trim panel. (Figure A)
2. Attach the pocket to the radio trim panel/brackets using the supplied four #8 x 3/8" Phillips screws. (Figure B)
3. Attach the aftermarket radio to the trim panel/pocket/bracket assembly using the ISO screws supplied with the radio. (Figure C)
4. Locate the factory wiring harness in the dash. Metra recommends using the proper mating adapter from Metra or AXXESS. Re-connect the negative battery terminal and test the unit for proper operation.
5. Reassemble dash in reverse order of disassembly.

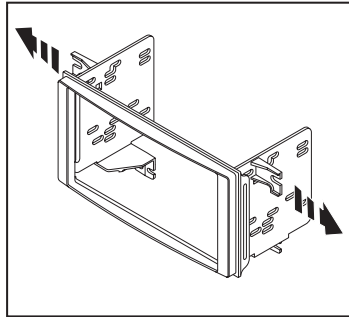

(Figure A)

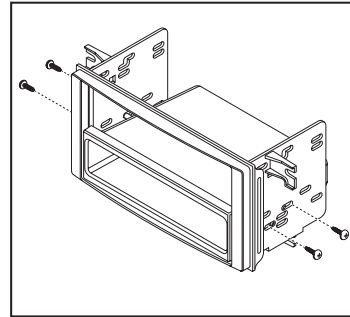

(Figure B)

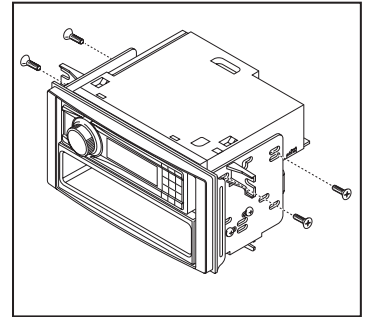

(Figure C)



INSTALLATION INSTRUCTIONS FOR PART 99-8905B

REV 11/27/2012 INST99-8905B



KNOWLEDGE IS POWER

Enhance your installation and fabrication skills by enrolling in the most recognized and respected mobile electronics school in our industry. Log onto www.installerinstitute.com or call 800-354-6782 for more information and take steps toward a better tomorrow.



Metra recommends MECP certified technicians



INSTRUCCIONES DE INSTALACIÓN PARA LA PIEZA 99-8905B

APLICACIONES

Subaru Impreza 2012 y mas 99-8905B

CARACTERÍSTICAS DEL KIT

- Provisión de unidad central ISO DIN con cavidad
- *Pintura negro mate*



COMPONENTES DEL KIT

- A) Panel de moldura para radio • B) Soportes para radio • C) Cavidad • D) Cuatro tornillos Phillips #8 de 3/8"

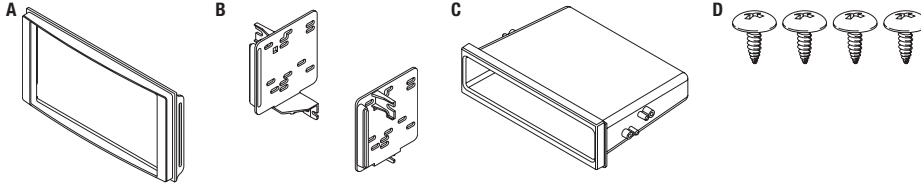

CABLEADO Y CONEXIONES DE ANTENA (se venden por separado)

- Arnés de cableado: • Arnés 70-7552 para Nissan 2007 y más recientes
Adaptador de antena: • No se requiere

HERRAMIENTAS REQUERIDAS

- Herramienta para quitar paneles • Destornillador Phillips • Pequeño destornillador de paleta

Indice

Desmontaje del tablero

- Subaru Impreza 2012 y mas 2

Ensamble del kit

- Provisión de unidad central ISO DIN con cavidad..... 3

PRECAUCIÓN: Metra recomienda desconectar el terminal negativo de la batería antes de comenzar cualquier instalación. Todos los accesorios, interruptores y, especialmente, las luces indicadoras de airbag deben estar enchufados antes de volver a conectar la batería o comenzar el ciclo de ignición.

Nota: Remítase a las instrucciones incluidas con el radio de posventa.

Desmontaje del tablero

1. Desconecte el cable selector de aire del lado del conductor de la consola central detrás del tablero sobre el pedal del acelerador. (Figura A, Figura B)
2. Abra la guantera y apriete hacia adentro los lados de la guantera para retirarla por completo. (Figura C)
3. Desconecte el cable selector de temperatura en el lado del pasajero de la consola central detrás de la guantera. (Figura C)

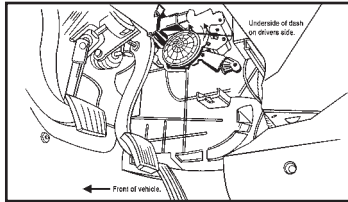

(Figura A)

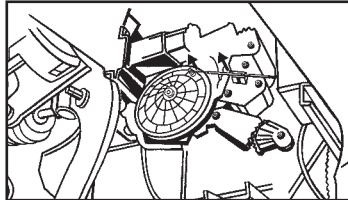

(Figura B)

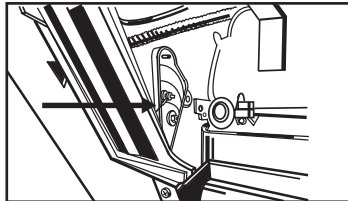

(Figura C)

4. Desenganche y quite el panel de moldura que rodea el radio de fábrica, incluyendo las rejillas del aire acondicionado y los controles de clima. (Figura D)
5. Quite los (4) tornillos Phillips del radio de fábrica. (Figura E)

Continuará la ensamble del kit

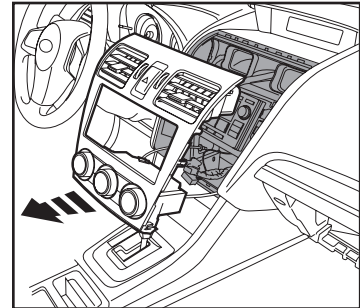

(Figura D)

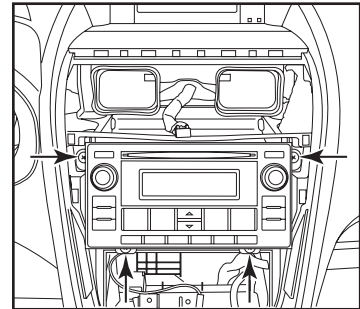

(Figura E)



99-8905B

Ensamble del kit

Provisiones de unidad central ISO DIN.

1. Una los soportes al panel de la moldura del radio. (Figura A)
2. Una la cavidad al panel de la moldura del radio/soportes usando los cuatro tornillos Phillips suministrados #8 x 3/8". (Figura B)
3. Una el radio al ensamble de panel de moldura/cavidad/soporte con los tornillos ISO que vienen con el radio. (Figura C)

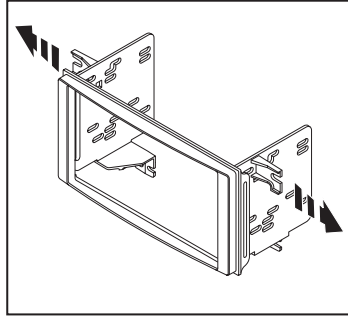

(Figura A)

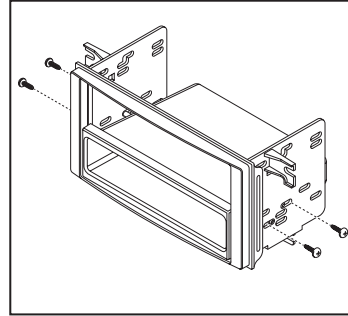

(Figura B)

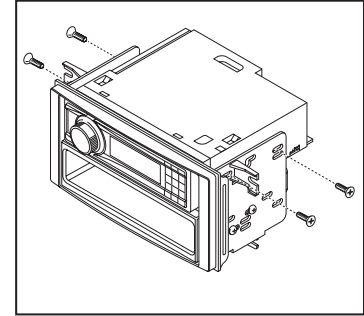

(Figura C)



INSTRUCCIONES DE INSTALACIÓN PARA LA PIEZA 99-8905B

REV 11/27/2012 INST99-8905B



EL CONOCIMIENTO ES PODER

Mejora sus habilidades de instalación y fabricación inscribiéndose en la escuela de dispositivos electrónicos móviles más reconocida y respetada de nuestra industria. Regístrese en www.installerinstitute.com o llame al 800-354-6782 para obtener más información y avance hacia un futuro mejor.



Metra recomienda técnicos con certificación del Programa de Certificación en Electrónica Móvil (Mobile Electronics Certification Program, MECP).